

Intermittent Extrusion Reciprocating Series

**400R11
400R20
400R25**

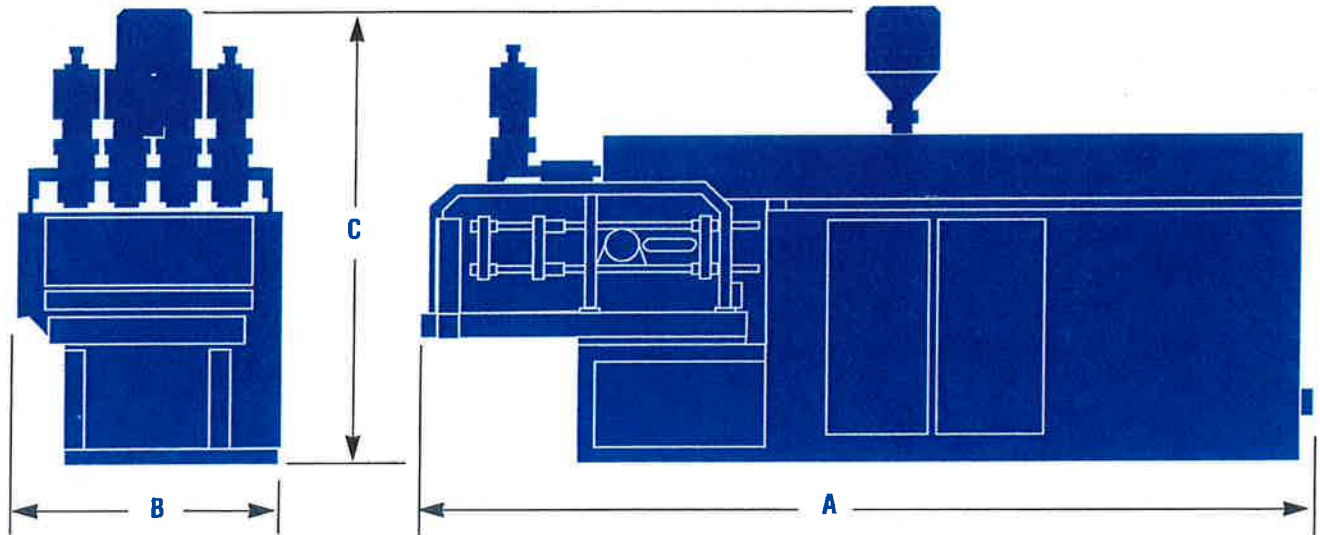

Note: This diagram may not be representative of all machines in the series.

	400R11/R20	400R25
A Max. configuration length** in. (mm)	244 (6,198)	258 (6,553)
B Max. configuration width** in. (mm)	116 (2,946)	90 (2,286)
C Max. configuration height in. (mm)	121 (3,073)	144 (3,658)
Max. configuration weight lbs. (kg)	42,000 (19,056)	40,000 (18,149)

** Approx. dimensions for extruder and clamp.

Specifications can't tell the whole story

- **Cost Effective**—In many applications, Uniloy Reciprocating machines are the most cost-effective blowmolding technology in the industry.
- **Low Maintenance/Long Tool Life**—Approximately 40% less moving parts than Shuttle technology. The results are reduced maintenance and improved mold life.
- **Versatility**—Uniloy Reciprocating machines can process several different types of resins in a wide variety of applications.
- **Experience**—Production-proven technology: 30 years, approximately 3,000 systems, with 90% still in use on 6 continents.
- **Special Builds**—Modular construction allows for the cost-competitive design and construction of custom machines to meet any product configuration and throughput demand.

**JOHNSON
CONTROLS**

Johnson Controls, Inc.
Plastics Machinery Division
10501 Highway M-52
Manchester, MI 48158
(313) 428-8371
(800) 666-8852
FAX: (313) 428-7095

Intermittent Extrusion Reciprocating Series

	400R11-R20	400R25	
Extruder	Screw Diameter in. (mm)	4 (102)	4 (102)
	Max. Screw Speed rpm	115	115
	L/D	24:1	24:1
	Throughput lbs./hr. (kg/hr.) [HDPE]	750/800 (340/363) [.96 density, .7 MI]	750/800 (340-363) [.96 density, .7MI]
	Drive Type	AC variable freq. DC drive (option)	AC variable freq. DC drive (option)
	Drive Size hp. (kW)	125-150 (93-112)	125-150 (93-112)
	Max. shot size gr HDPE	1,100 [R11] 2,000 [R20]	2,500
	Barrel Cooling Type	Oil	Oil
Oil tank capacity gal. (l)	98 (370)	98 (370)	
Melt Delivery	Number of Heads	1-12	1-12
	Center Spacing in. (mm)	4-22 (102-559)	4-22 (102 -559)
	Maximum Tooling Size in. (mm)	6 (152)	6 (152)
Clamp	Max. Clamp Stroke in. (mm)	11.8-16-20 (300-406-508)	11.8-16-20 (300-406-508)
	Distance between Tie Bars* in. (mm)	15 x 45 Dbl. (381 x 1,143) Maximum	15 x 45 Dbl. (381 x 1,143) Maximum
	Min. Mold Shut Ht. in. (mm)	6.2-9-12 (158-229-305)	6.2-9-12 (158-229-305)
	Max. Mold Shut Ht. in. (mm)	11.7-18-24 (297-457-610)	11.7-18-24 (297-457-610)
	Usable Platen Area H x W in. (mm)	2-15 x 45 (2-381 x 1,143)	2-15 x 45 (2-381 x 1,143)
	Clamp Tonnage US (Metric)	90 (82)	90 (82)
Utilities	Total Connected Load kW	219/241	219/241
	Typical Electrical Running Load kW	144/163	144/163
	Chilled Water °F-psi-gpm (°C-bar-l/min.)	35-65-115 (2-4.9-435)	35-65-115 (2-4.9-435)
	Min. Air SCFM-psi (l/min.-bar)	80-100 (2,264-6.9)	80-100 (2,264-6.9)

* E.C. machine max. clamp size only.

- Ongoing improvements may alter specifications.
- The company reserves the right to modifications and variations of any type for technical and aesthetic reason.
- Approximate rates, actual rates vary with resin and process conditions.

